



Divider Rounder Rollrex R30

ROLLREX has been designed and built with the baker in mind which is why you can expect to get many years of trouble free operation.

The R series are Semi-automatic: Pressing, dividing and rounding (floating plate motorized) working cycle by levers.

RollRex®



- Structure in stainless steel 18/10 oven-painted
- Stainless steel knives
- Head and dividing disc in cast aluminium for food
- Synthetic rounding plate for food
- Divides and rounds soft or firm dough's
- Low power consumption .55 kW
- Small space requirements
- Easy to remove top covers for ease of cleaning
- Machine total manufactured in Stainless Steel to eliminate rusting
- The head of machine can be tilted for ease of cleaning
- Easy maintenance, no lubrication required
- Machine supplied with 3 x hygiene moulding plates
- Production up to 12.000 pieces per hour cut only or 10,000 per hour dividing and rounding
- Supplied on wheels with lock downs for sturdy operation

The ROLLREX divider rounder represents the best value money can buy.

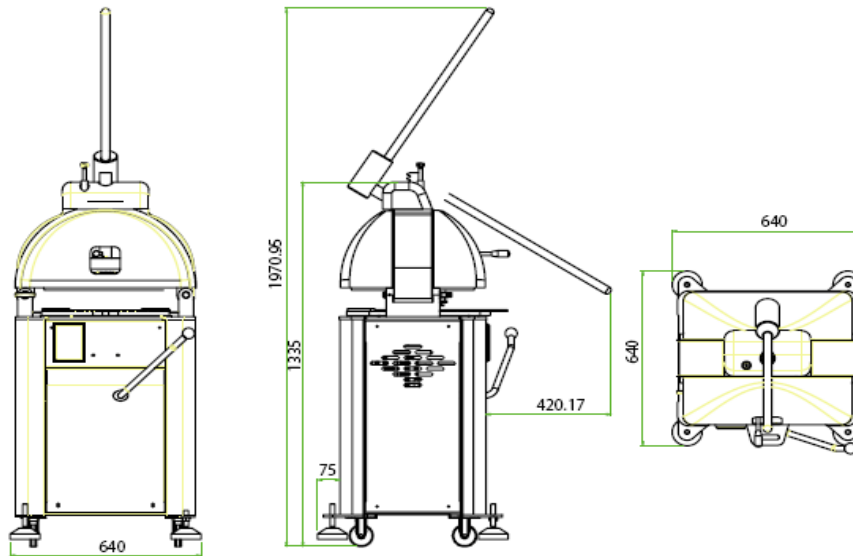

Rollrex R30 Divider Rounder	
Divisions	30
Dough Weight	40-135
Capacity	4 Kg
Aperture Opening	70mm
Weight	360Kg
Power	0.55 Kw

Your Bakery/Pizza Equipment Specialists.

122 Whitehorse Road, Blackburn, Victoria, Australia. 3130

abpatlas@abpatlas.com.au Tel: +61 3 9878 6900 Fax: +61 3 9878 6966