

Convection Ovens Europa Newton

The new range of convection ovens, called **NEWTON**, has been realized according to the more recent technical/scientific considerations, in order to find the best solutions for baking the most important types of bread, as well as for being perfectly suitable both in the traditional and modern confectionery. It was conceived to satisfy the needs of the most qualified bakers and confectioners. It's available with a wide range of options:

Options

- The computerized digital panel.
- The double speed fan.
- The hood equipped with steam exhauster.
- The thermostatic prover for ten trays with the possibility to add the manual humidity control.
- Various types of supports and pivoting castors.
- For the most exacting users, there is also the possibility to have the instantaneous steam generator.



Your Bakery/Pizza Equipment Specialists.

122 Whitehorse Road, Blackburn, Victoria, Australia. 3130

abpatlas@abpatlas.com.au Tel: +61 3 9878 6900 Fax: +61 3 9878 6966

Australian Bakery & Pizza

Importers and Distributors



Newton Convection Oven Technical Specifications

Model	Type	Capacity	Dimensions (millimetre)			Voltage	Power
			Width	Height	Depth		
N5T	Convection Oven	4/5 (40 x 60)	1040	700(+40)	855	415-50Hz	8Kw
N10T	Convection Oven	8/10 (40 x 60)	1040	1150(+40)	855	415-50Hz	16Kw
E2T330	Deck Oven	2 (40 x 60)	1040	330	1155	415-50Hz	6Kw + 2Kw
NMC 200	Hood		1040	200	+300	240-50Hz	0.15Kw
NC 725	Prover	10 (40 x 60)	1040	725	795	240-50Hz	2Kw (+2Kw)

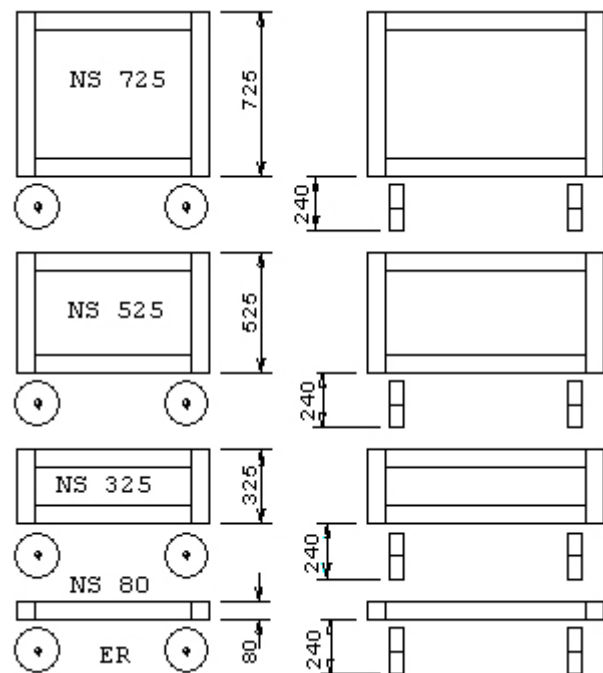
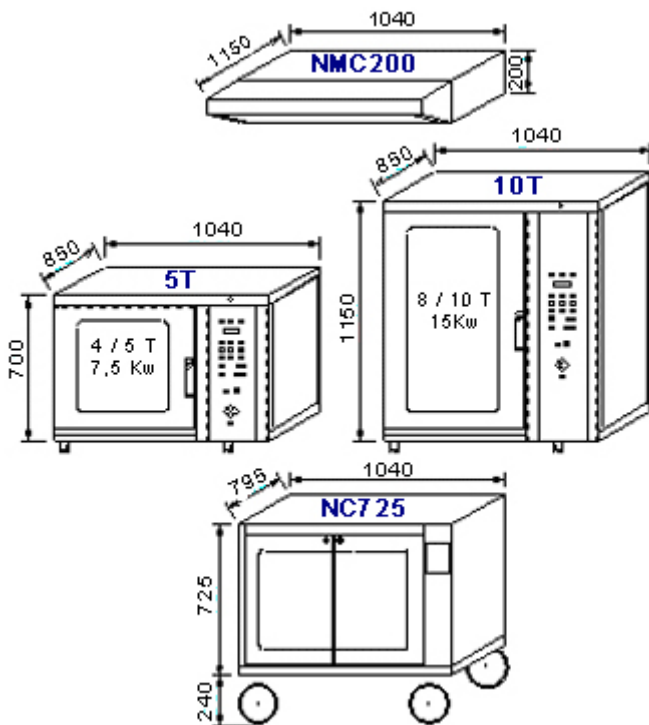

Your Bakery/Pizza Equipment Specialists.

122 Whitehorse Road, Blackburn, Victoria, Australia. 3130

abpatlas@abpatlas.com.au Tel: +61 3 9878 6900 Fax: +61 3 9878 6966