

LP Lynx Self Emptying Spiral Mixers

Description

Self-emptying spiral mixers lines, composed of spiral mixer with fixed bowl and hydraulic lifter.

Dough capacity from 120 kg to 200 kg and fitted with 2 motors on the spiral mixer and 1 motor on the lifter. Spiral Action is dual speed with bowl inversion available on the first speed.

Easy dough extraction thanks to the bowl jog push-button. Control panel choice between two electro-mechanical timers SITEC 72x72 or electronic control panel + bypass selector. Mobile bowl cover choice among: stainless steel grid, ABS mobile bowl cover, transparent PMMA mobile,

Discharge on one side only -choice between right or left. Two possible discharge heights: onto table at 1400 mm (model LYNX-B) or into divider at 1900 mm (model LYNX-T) LYNX Line conceived for dough mixtures with hydration greater than 55% with European flour.

LYNX-R Line, equipped with double spiral transmission, straight breaking bar and reinforced spiral motor and then conceived for stiffer dough mixtures with hydration greater than 45% with European flour Lines suitable for an artisan use (3 cycles per hour, 10-12 hours per day).

Available control panels: two electro-mechanical timers Sitec 72x72 or electronic control panel + bypass selector.



LP Lynx Self Emptying Spiral Mixers

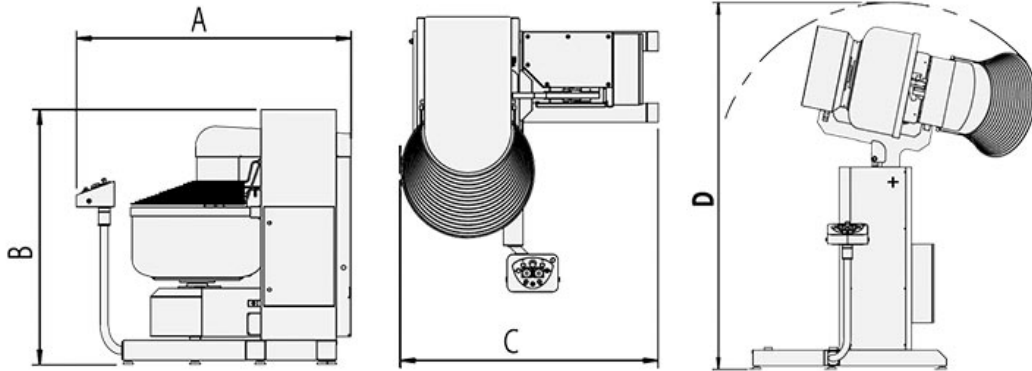

LP Lynx Self Emptying Spiral Mixers – Specifications

Model	Lynx 120	Lynx 160	Lynx 200
Min/Max Dough Capacity (Kg)	10/120	10/160	10/200
Flour Capacity (Kg)	75	100	125
Bowl Volume (L)	188	266	306
Spiral Motor Power (kW)	2.6 - 4.8 (Lynx 120) 3.0 - 6.2 (Lynx-R 120)	5.9 - 10.3 (Lynx 160) 6.0 - 12.0 (Lynx-R 160)	5.9 - 10.3 (Lynx 200) 6.0 - 12.0 (Lynx-R 200)
Bowl Motor Power (kW)	0.55	0.75	0.75
Hydraulic Unit Motor (kW)	1.5	1.5	1.5
Dimensions AxBxC Lynx-B (mm)	1835 x 1510 x 1760	1935 x 1615 x 1780	1935 x 1615 x 1815
Maximum Height Lynx-B (mm)	2460	2620	2660
Dimensions AxBxC Lynx-T (mm)	1835 x 1730 x 1760	1935 x 1730 x 1780	1935 x 1730 x 1815
Maximum Height Lynx-T (mm)	2985	3150	3200
Approx. Weight Lynx-B (kg)	1045	1235	1245
Approx. Weight Lynx-T (kg)	1175	1365	1375